

# 80mm Sliding

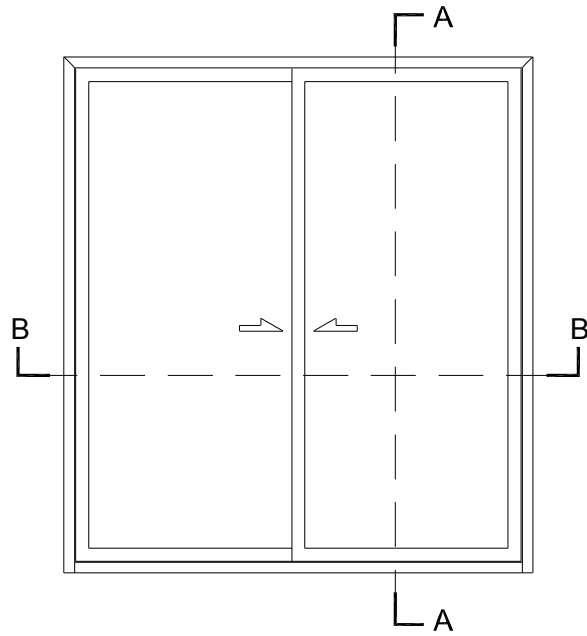

ELEVATION

SECTION:- A-A

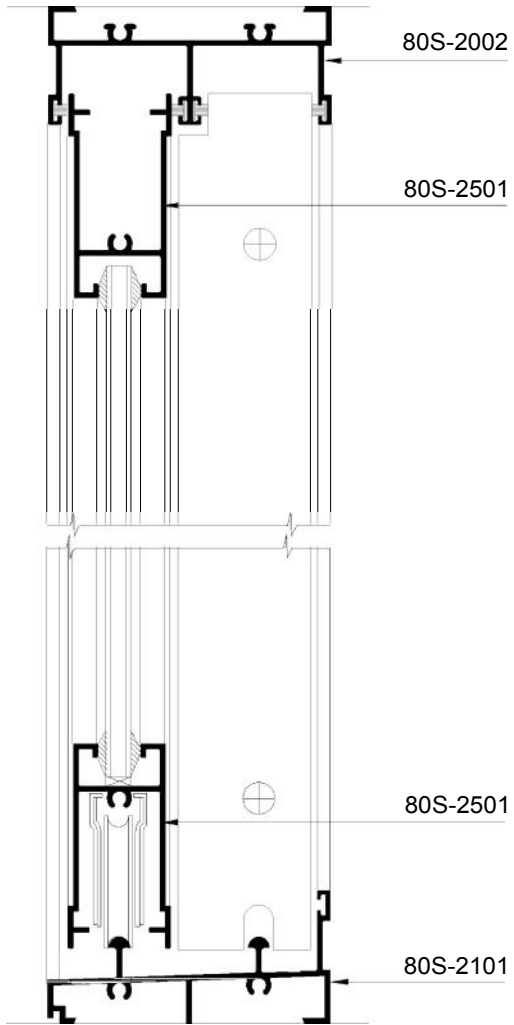
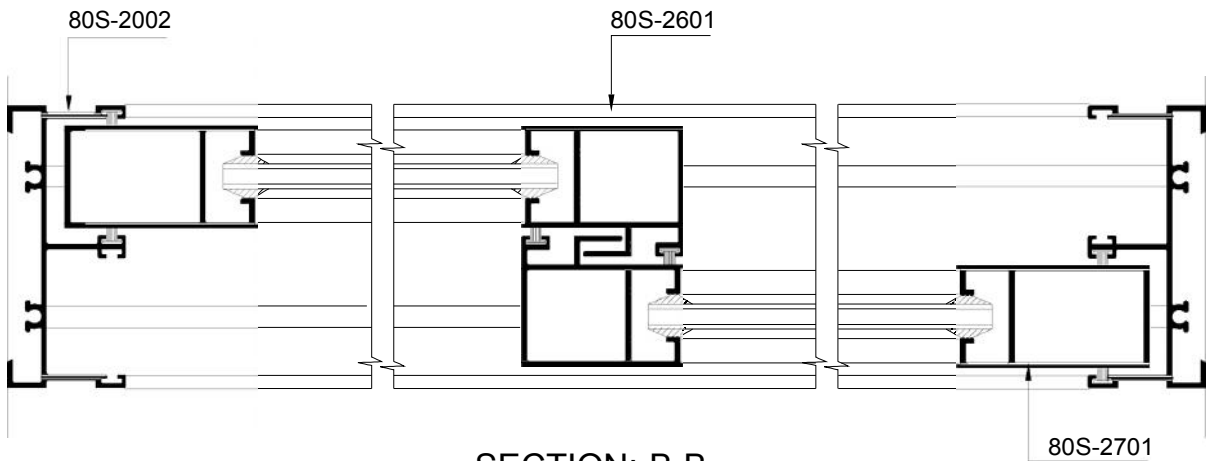

SECTION:- B-B

# 80mm Sliding

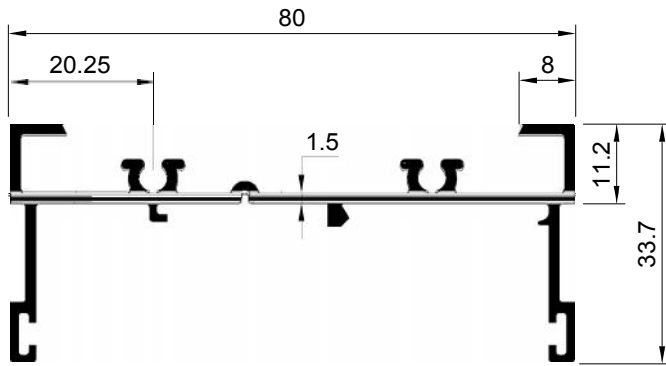

SECTION NO. - 80S-2001  
EST. WEIGHT - 0.821 KG./M.

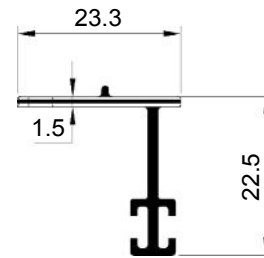

SECTION NO. - 80SFL-1001  
EST. WEIGHT - 0.224 KG./M.

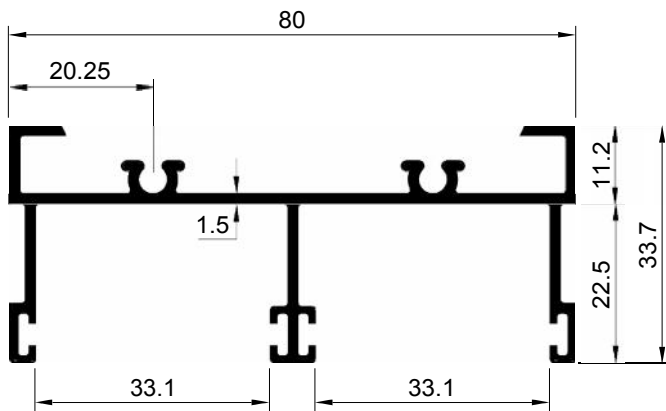

SECTION NO. - 80S-2002  
EST. WEIGHT - 0.911 KG./M.

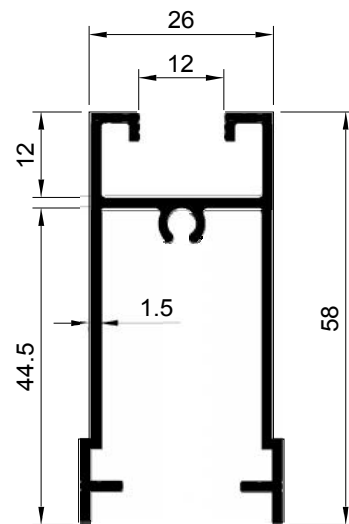

SECTION NO. - 80S-2501  
EST. WEIGHT - 0.717 KG./M.

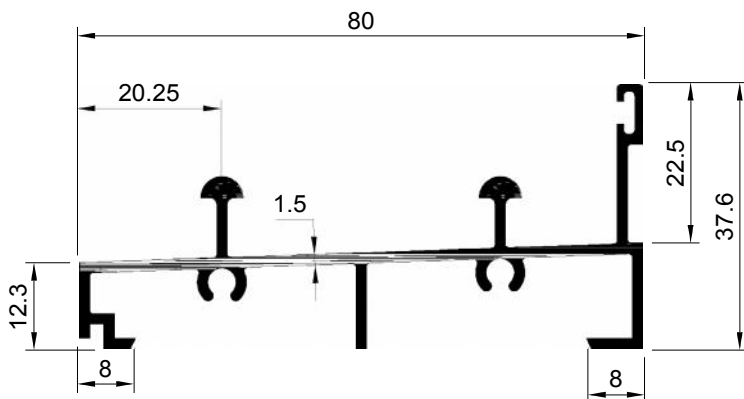

SECTION NO. - 80S-2101  
EST. WEIGHT - 0.866 KG./M.

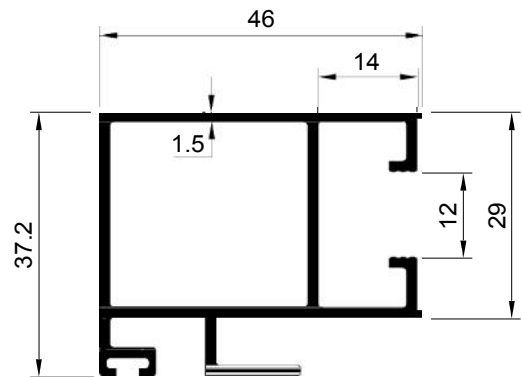

SECTION NO. - 80S-2601  
EST. WEIGHT - 0.803 KG./M.

# 80mm Sliding

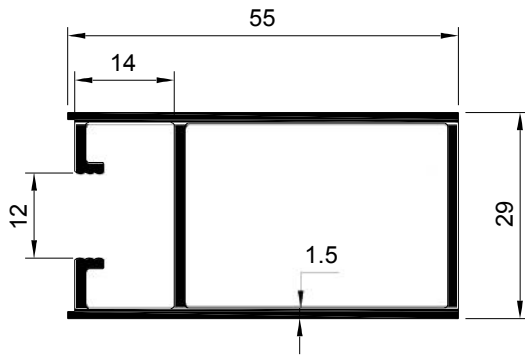

SECTION NO. - 80S-2701  
EST. WEIGHT - 0.723 KG./M.

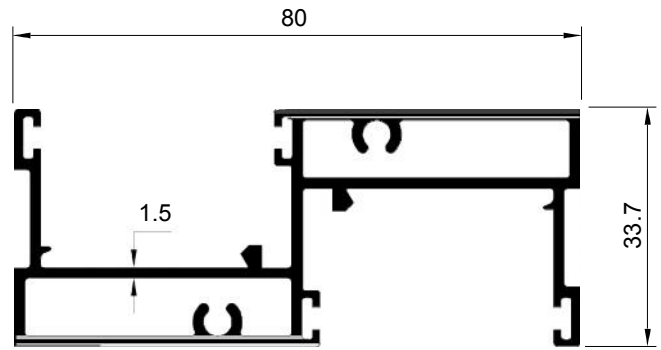

SECTION NO. - 80S-2201  
EST. WEIGHT - 1.237 KG./M.

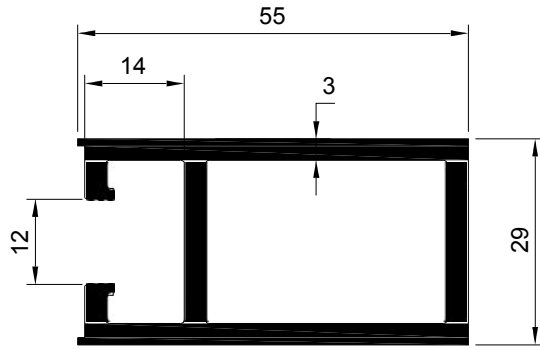

SECTION NO. - 80S-2701 H  
EST. WEIGHT - 1.350 KG./M.

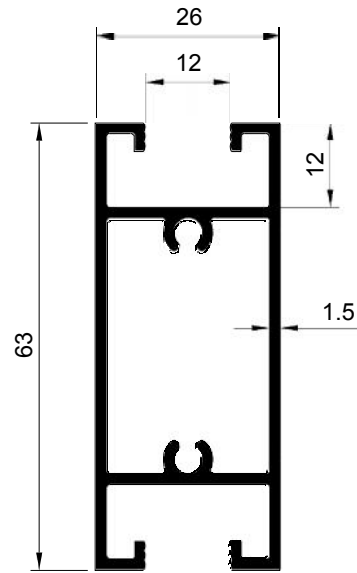

SECTION NO. - 80S-2801  
EST. WEIGHT - 0.908 KG./M.

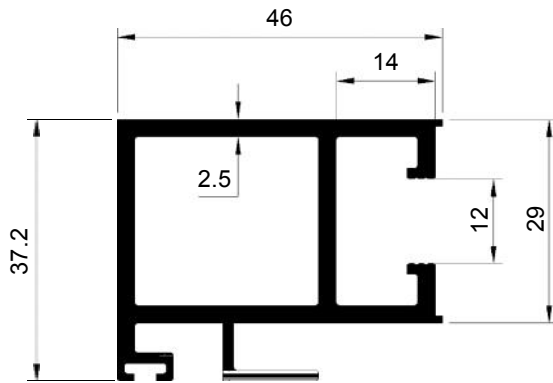

SECTION NO. - 80S-2601 H  
EST. WEIGHT - 1.194 KG./M.

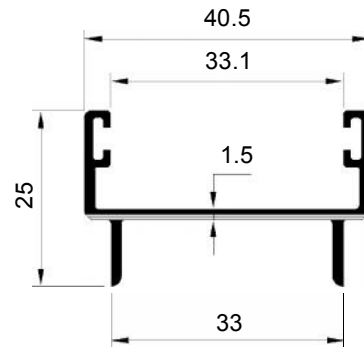

SECTION NO. - 80S-2901  
EST. WEIGHT - 0.379 KG./M.

# 80mm Sliding

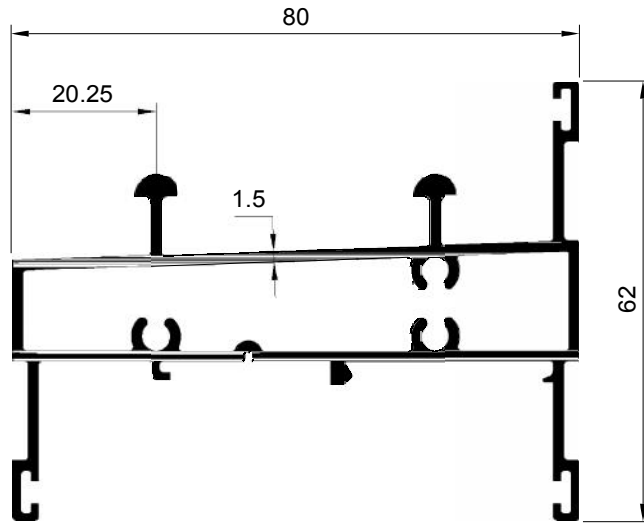

SECTION NO. - 80S-2301  
EST. WEIGHT - 1.390 KG./M.

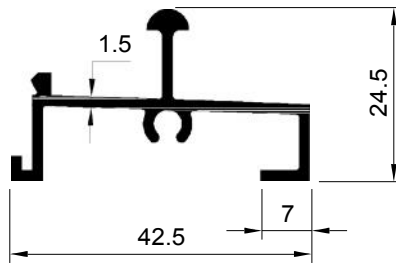

SECTION NO. - SS-2101  
EST. WEIGHT - 0.427 KG./M.

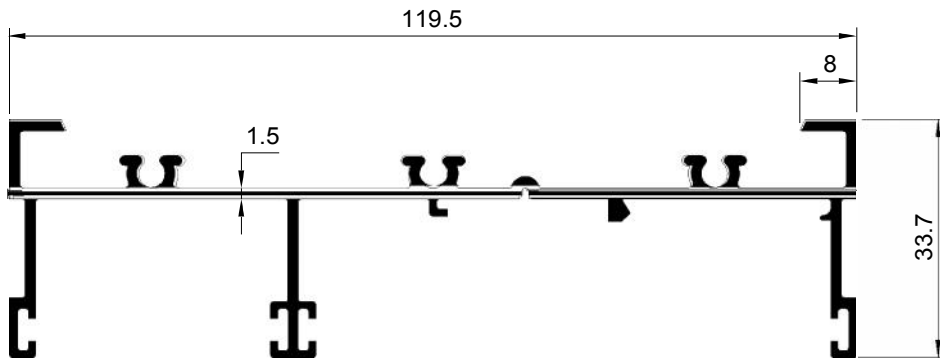

SECTION NO. - 80S-2001A  
EST. WEIGHT - 1.167 KG./M.

# 3D Assembly Detail Of 80mm Sliding

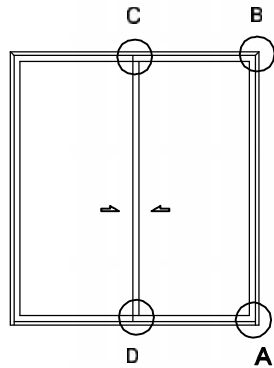

Elevation

80S-2002

Detail - "B" Head & Jamb Joint

S/T Screw

80S-2101

Out Side

In Side

Detail - "A" Sill & Jamb Joint

S/T Screw

Rubber Beading

80S-2601

80S-2501

Rubber Beading

Glass

80S-2701

S/T Screw

Cap

80S-2501

80S-2601

Detail - "A", "B" & "C", "D"  
Sash Joint

Roller

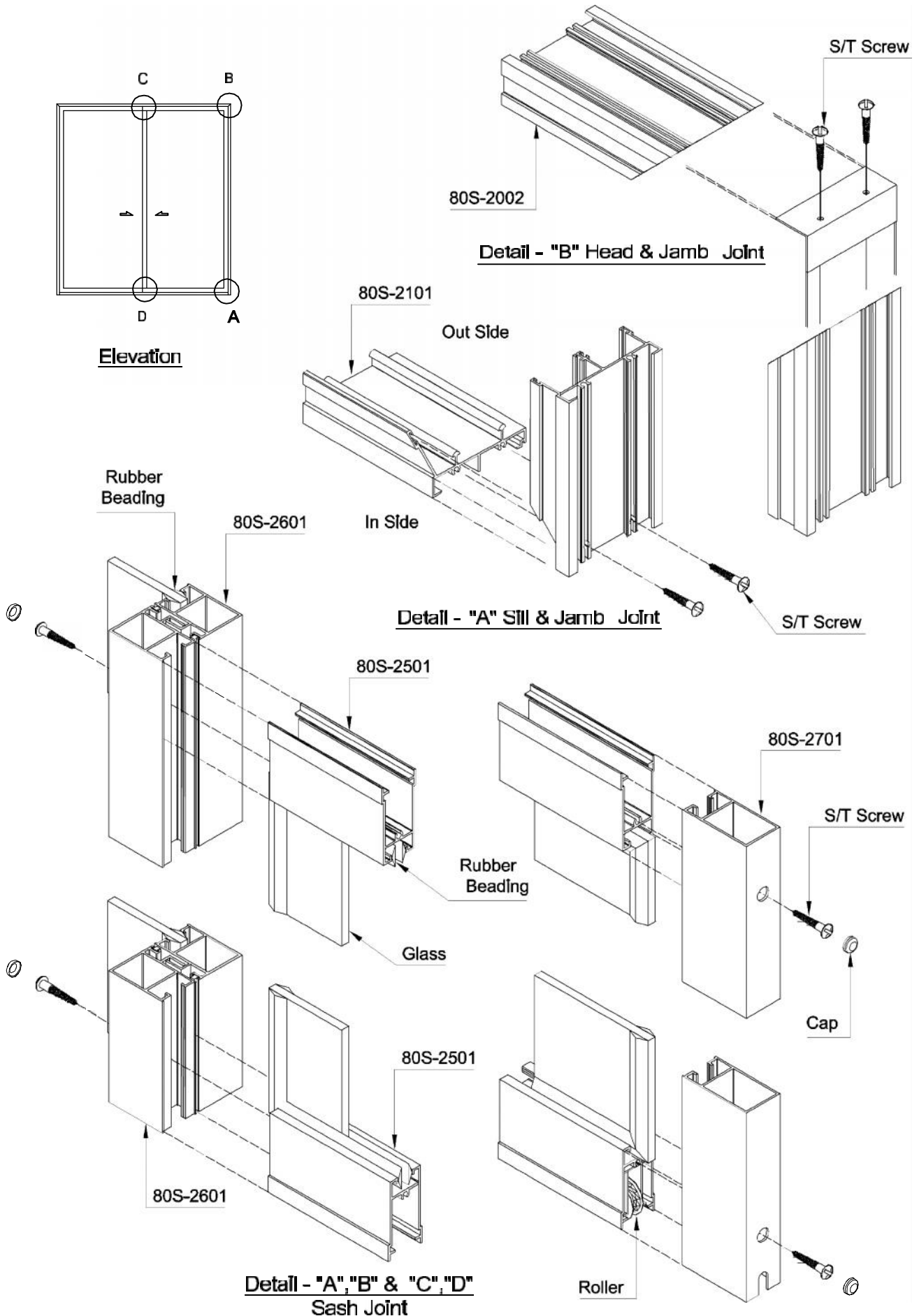

# 80mm Sliding

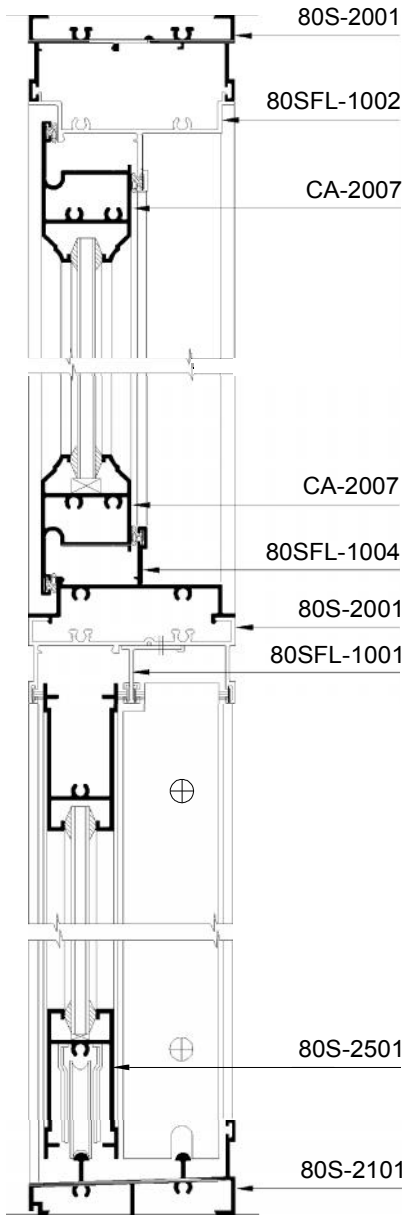

SECTION:- A-A

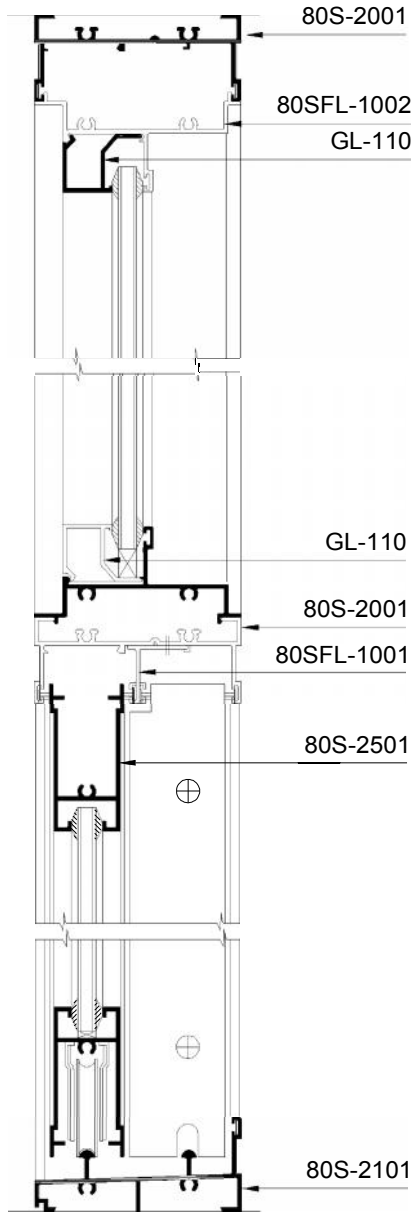

SECTION:- B-B

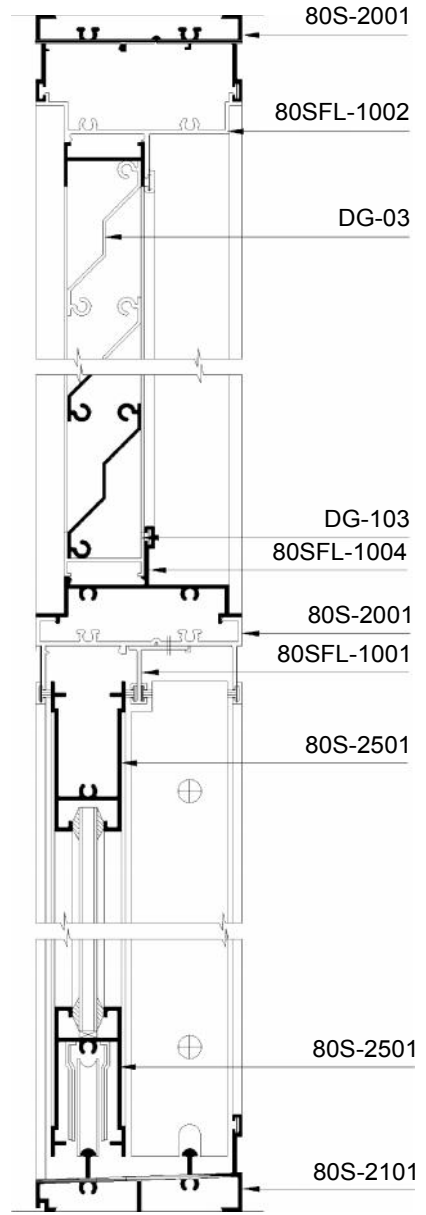

SECTION:- C-C

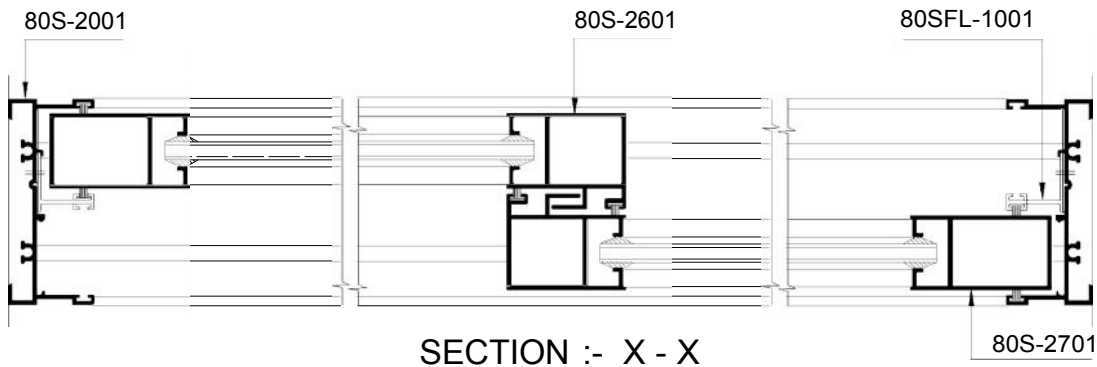

SECTION :- X - X

# 80mm Sliding

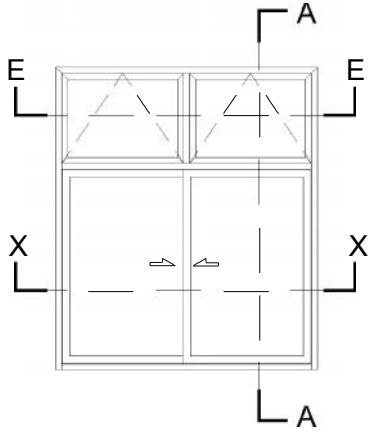

SLIDING WITH  
TOP HUNG

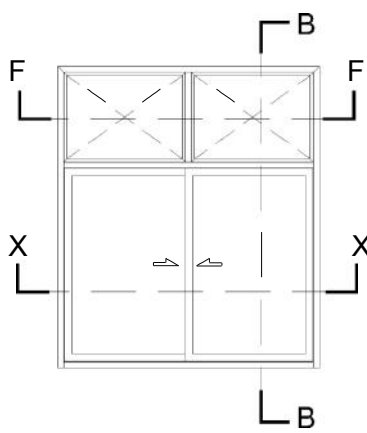

SLIDING WITH  
TOP FIXED

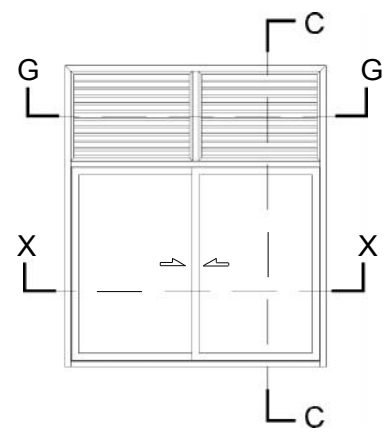

SLIDING WITH  
TOP LOUVER

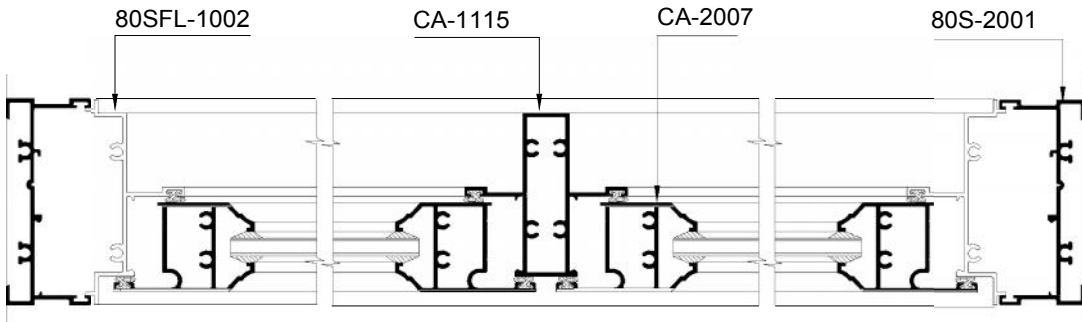

SECTION :- E - E

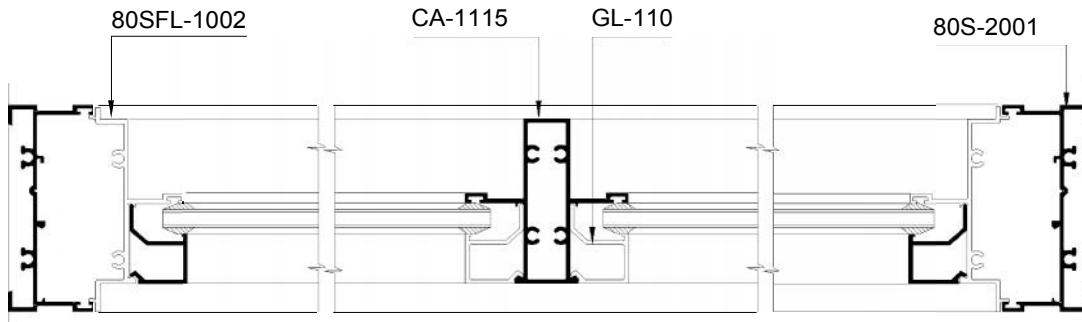

SECTION :- F - F

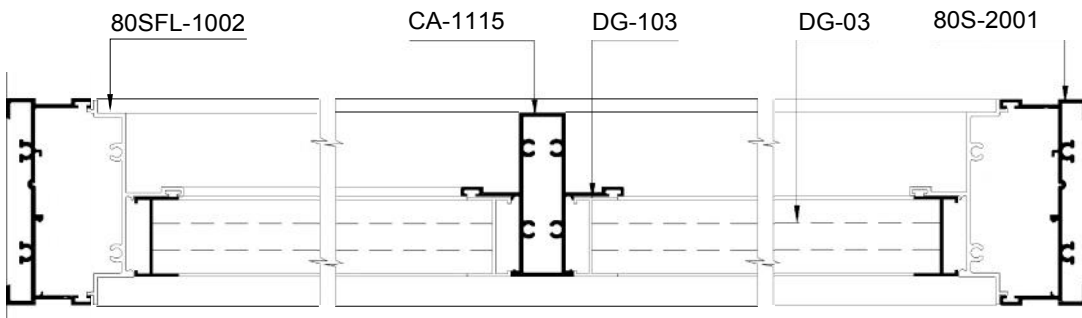

SECTION :- G - G

# 80mm Sliding

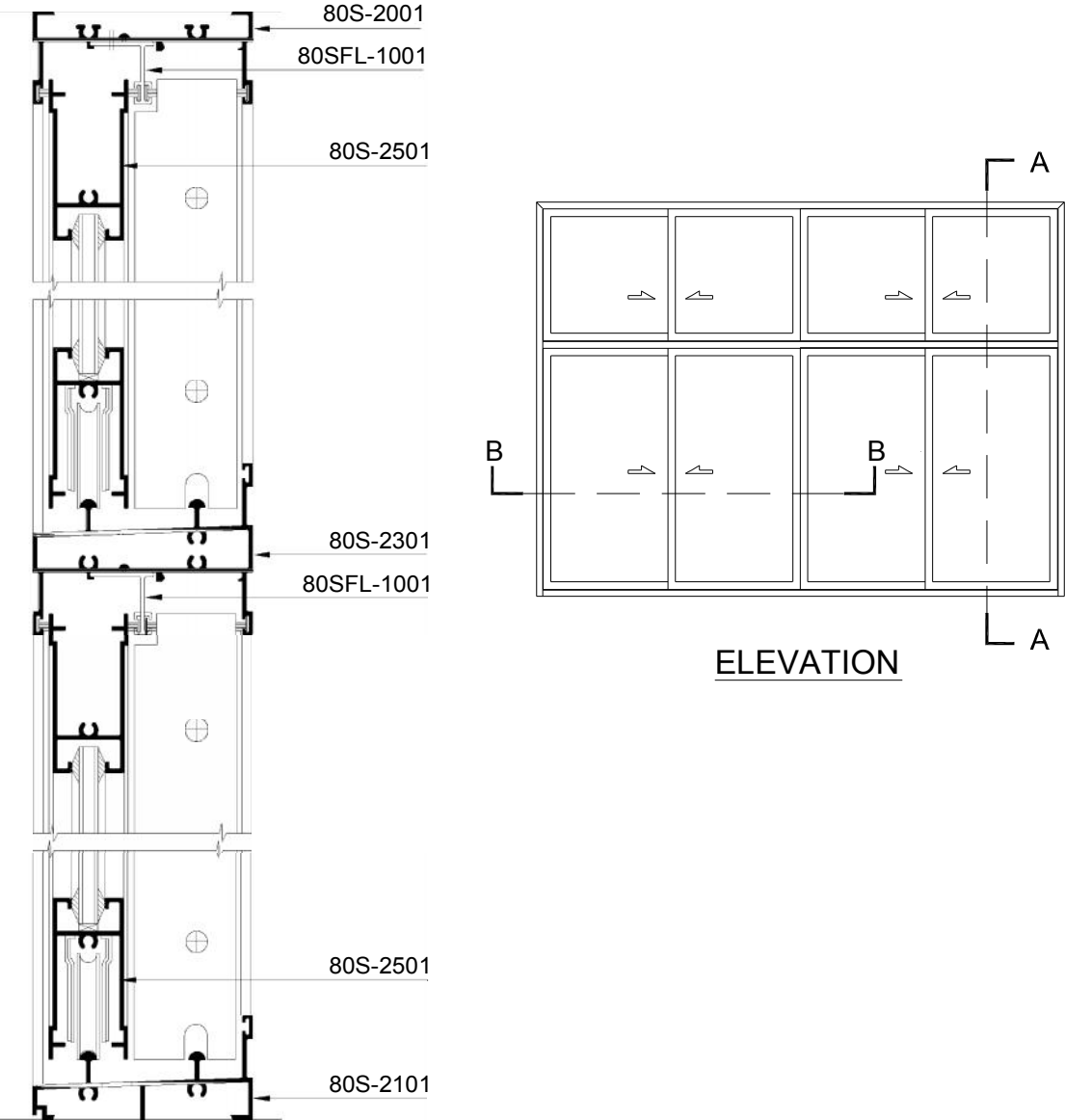

SECTION:- A-A

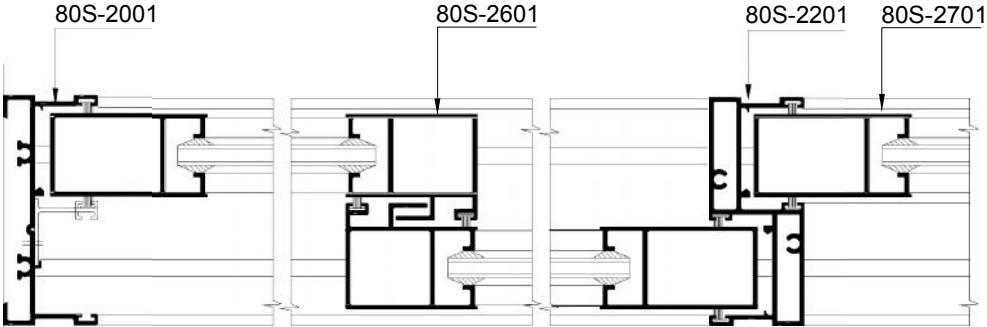

SECTION :- B - B



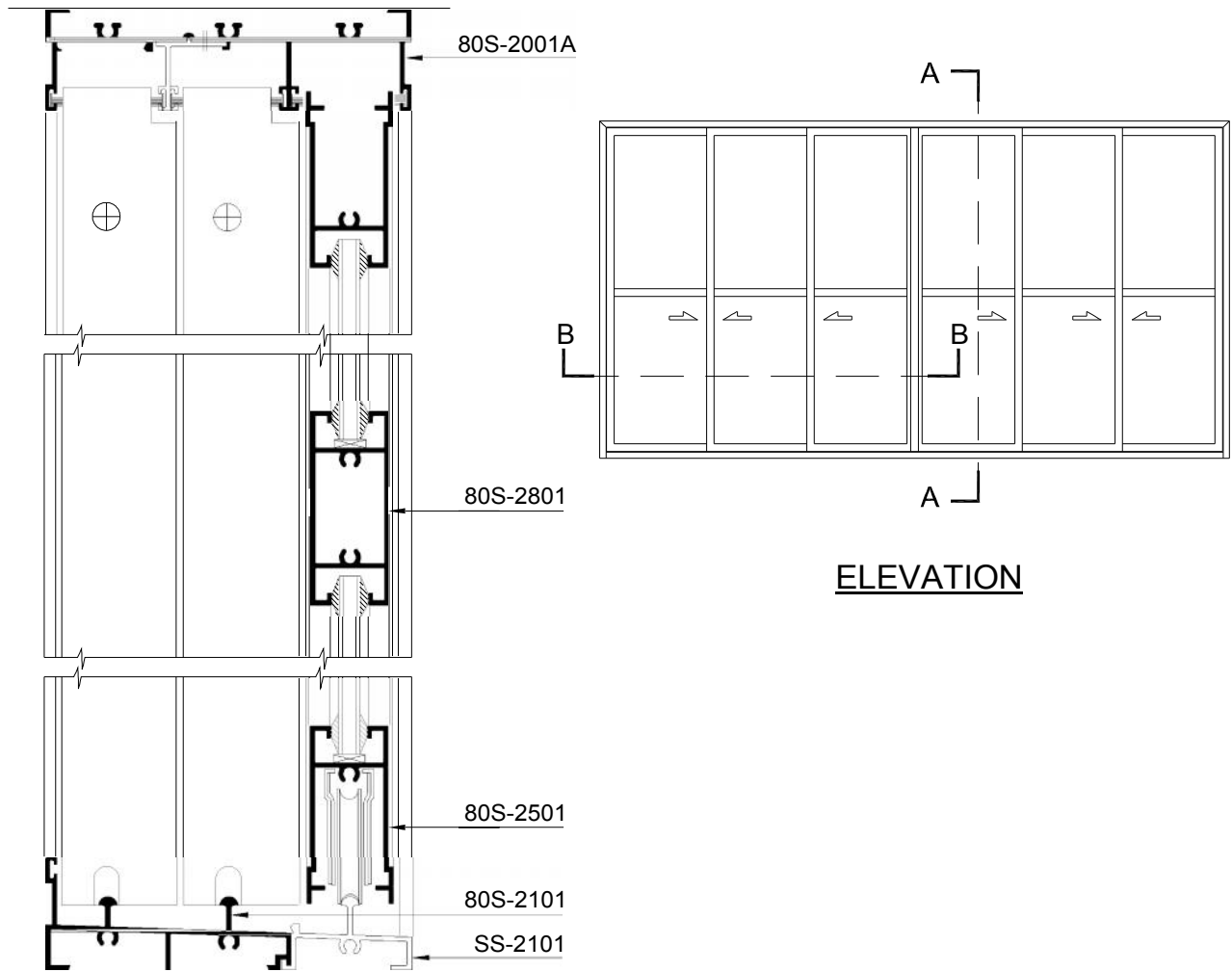

SECTION:- A-A

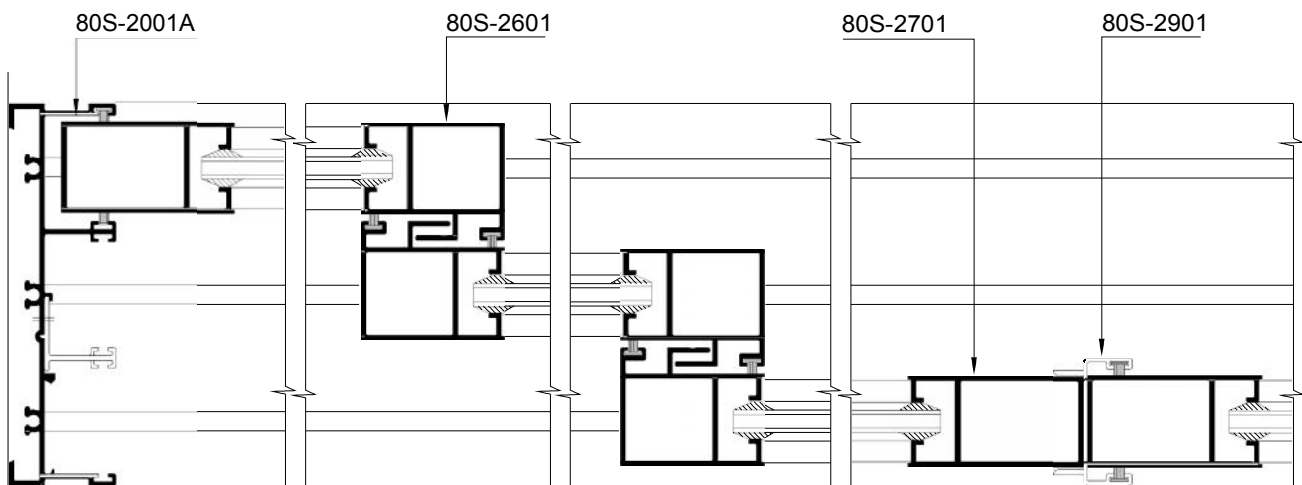

SECTION :- B - B

# 80mm Sliding & Fixed

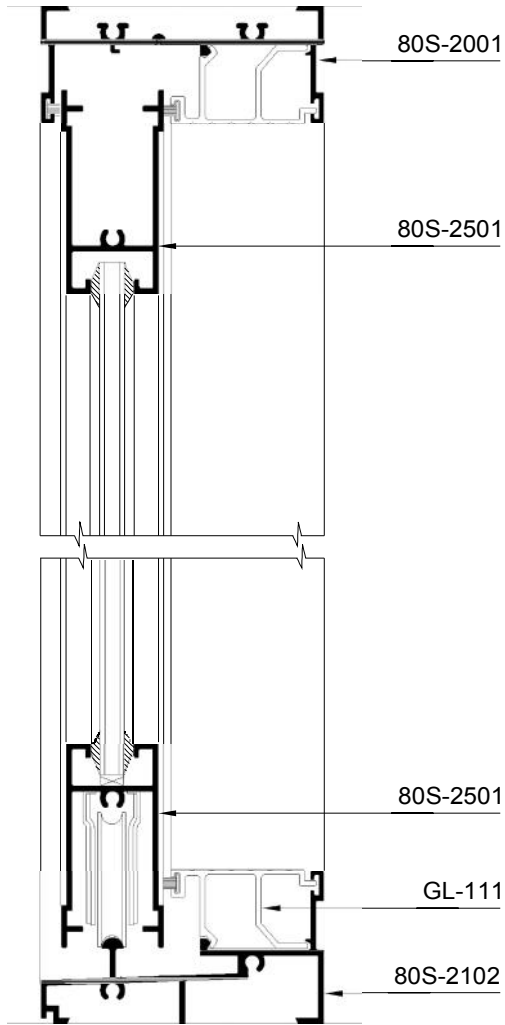

SECTION:- A-A

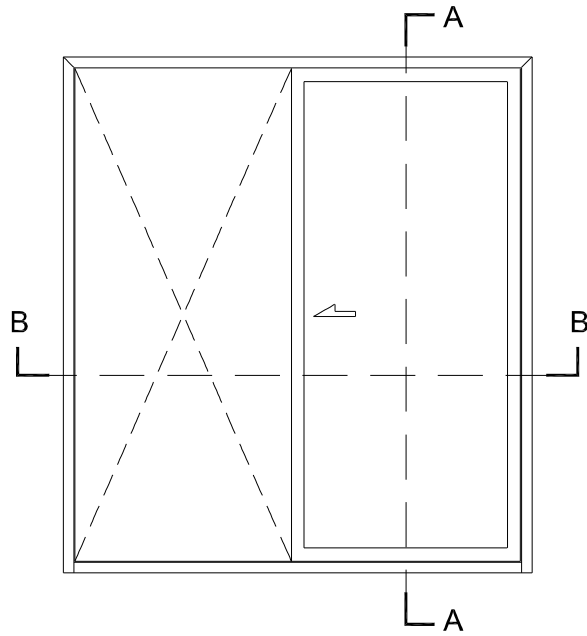

ELEVATION

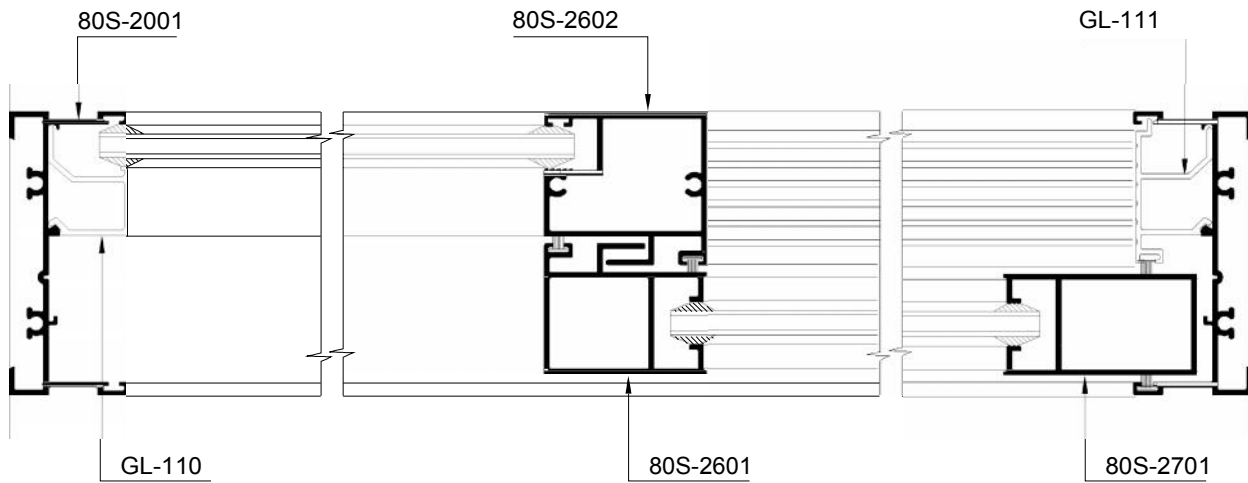

SECTION:- B-B

# 80mm Sliding & Fixed

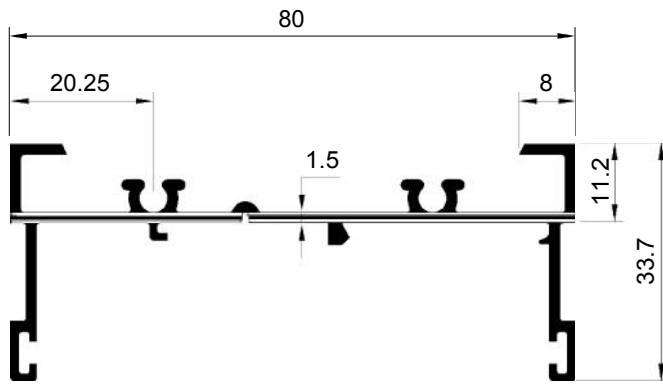

SECTION NO. - 80S-2001  
EST. WEIGHT - 0.821 KG./M.

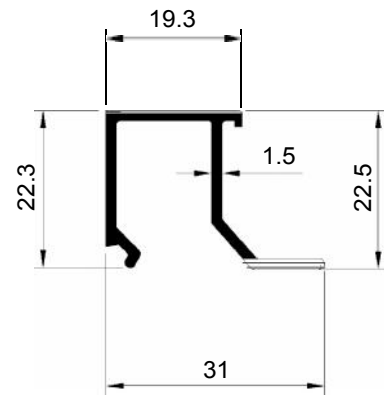

SECTION NO. - GL-110  
EST. WEIGHT - 0.305 KG./M.

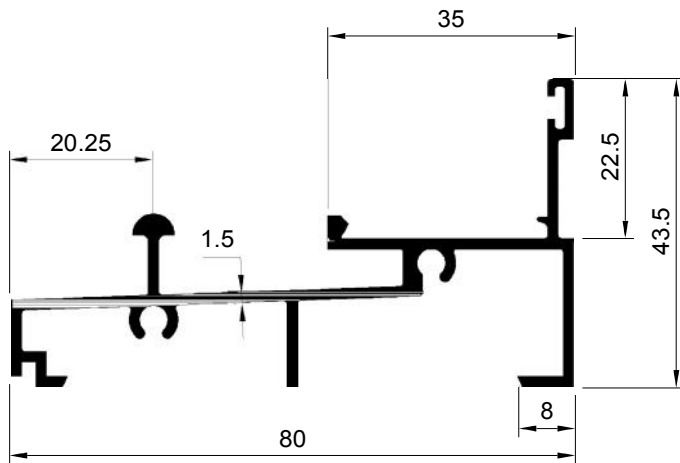

SECTION NO. - 80S-2102  
EST. WEIGHT - 0.914 KG./M.

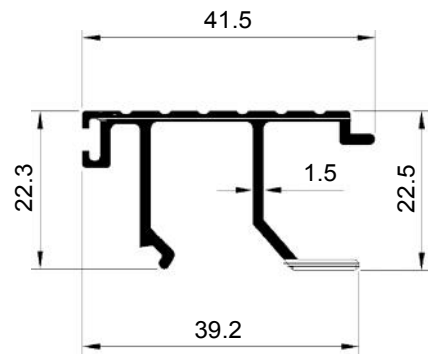

SECTION NO. - GL-111  
EST. WEIGHT - 0.435 KG./M.

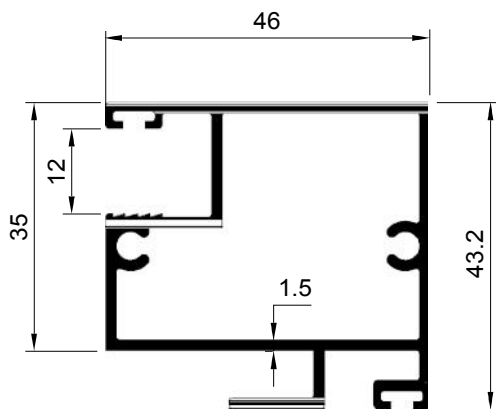

SECTION NO. - 80S-2602  
EST. WEIGHT - 0.941 KG./M.

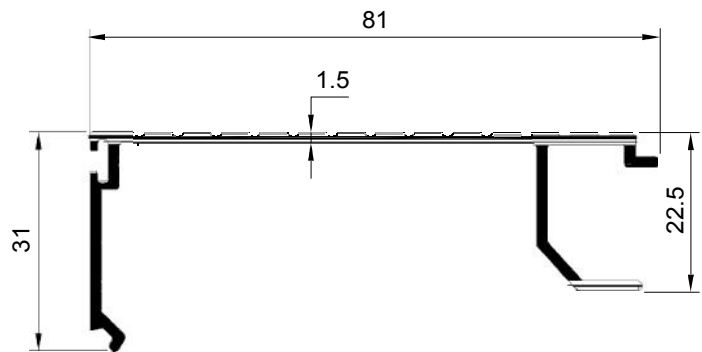

SECTION NO. - GL-112  
EST. WEIGHT - 0.588 KG./M.

# 80mm Sliding & Fixed

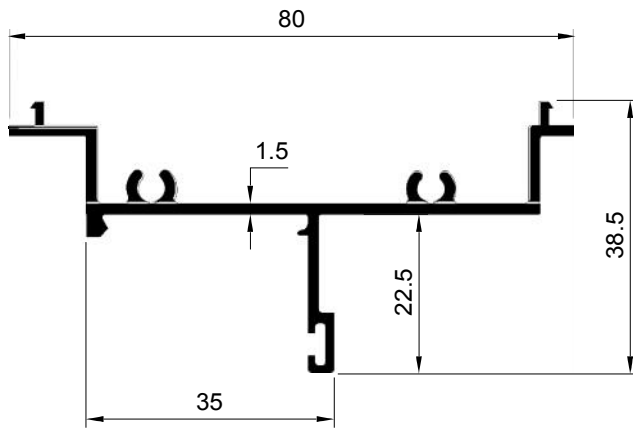

SECTION NO. - 80SFL-1002  
EST. WEIGHT - 0.655 KG./M.

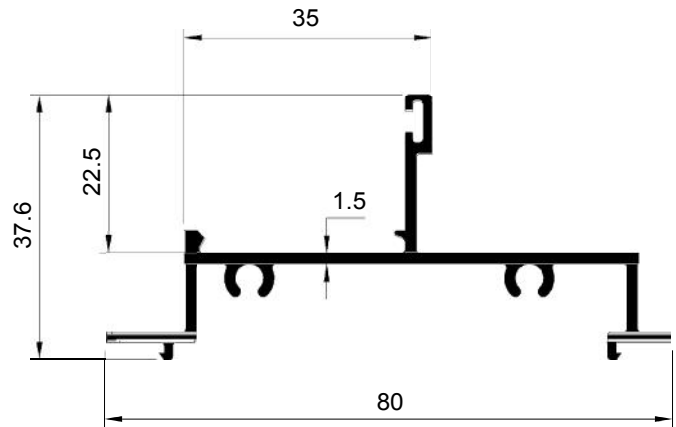

SECTION NO. - 80SFL-1004  
EST. WEIGHT - 0.660 KG./M.

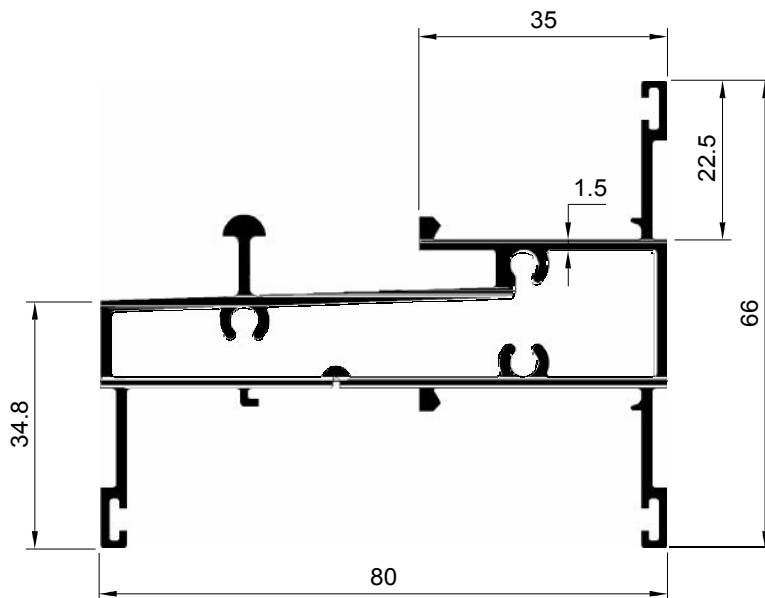

SECTION NO. - 80S-2302  
EST. WEIGHT - 1.423 KG./M.

# 80mm Sliding & Fixed (Louver)

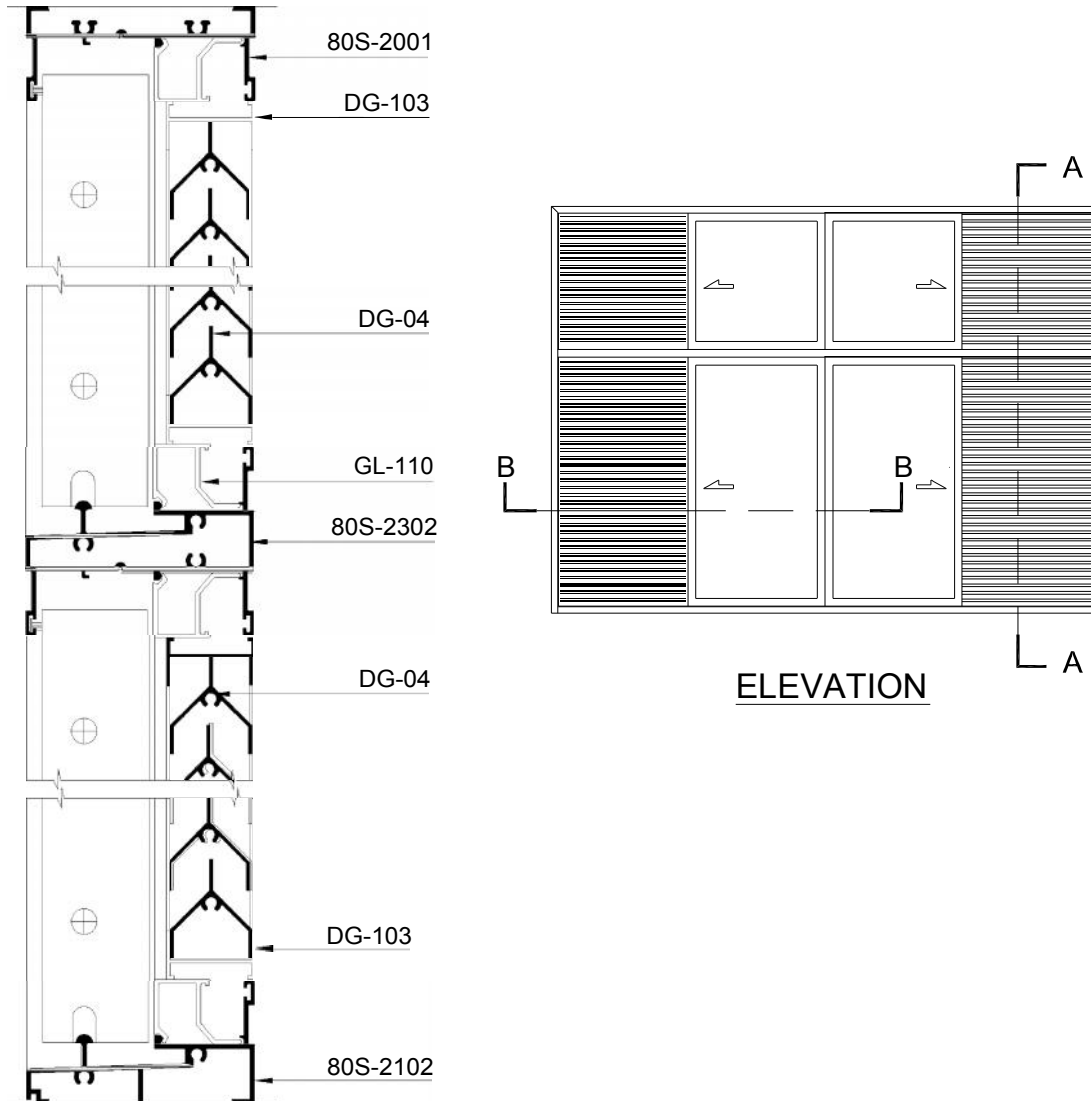

## SECTION:- A-A

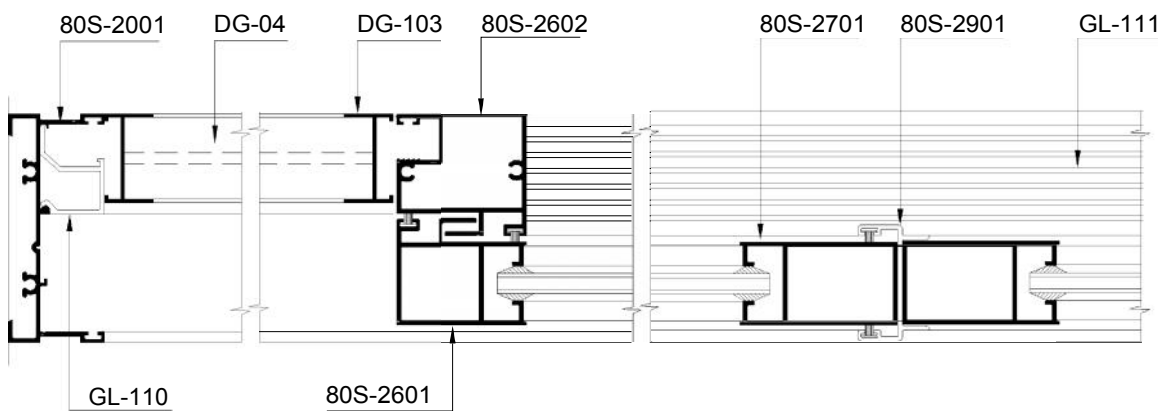

## SECTION:- B-B

# 3D Assembly Detail Of 80mm Sliding Fixed

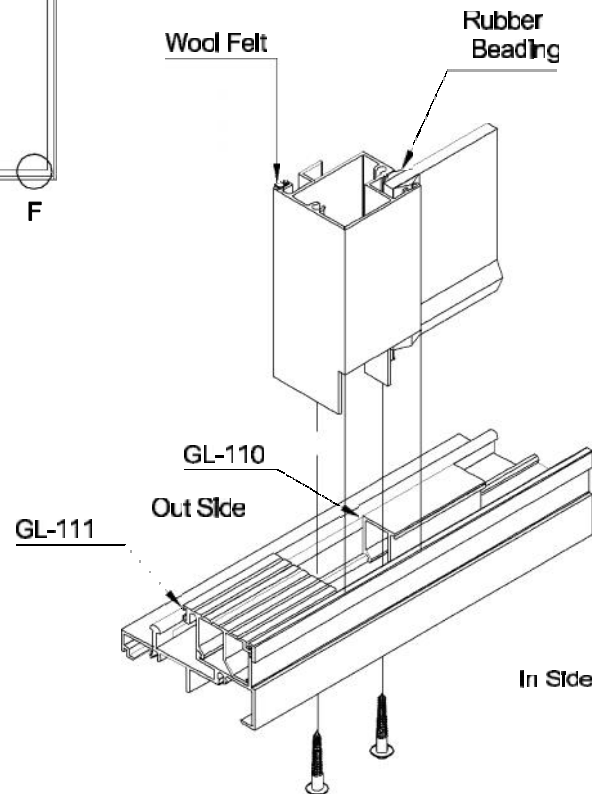
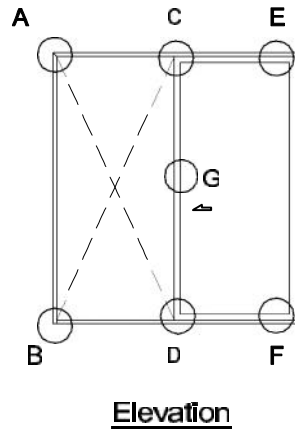
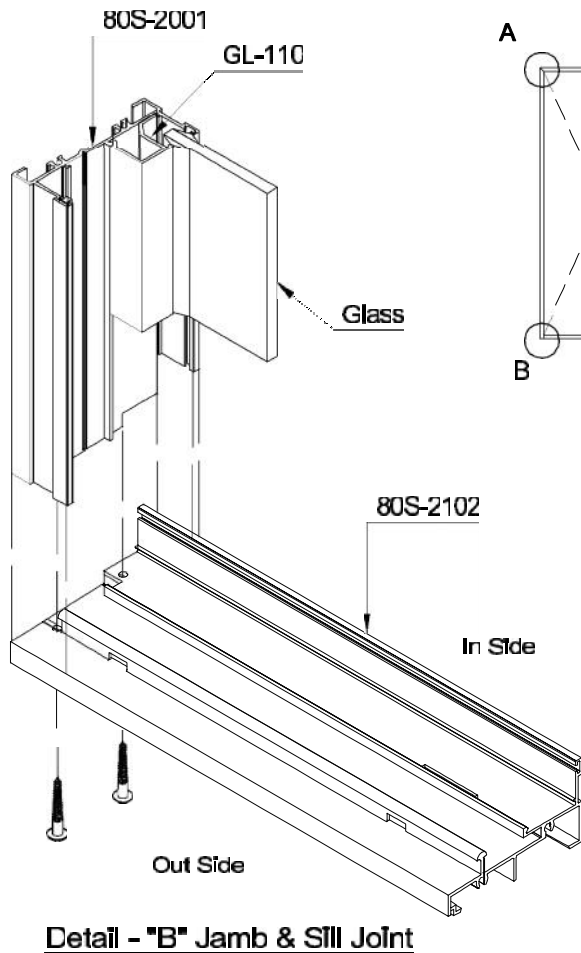
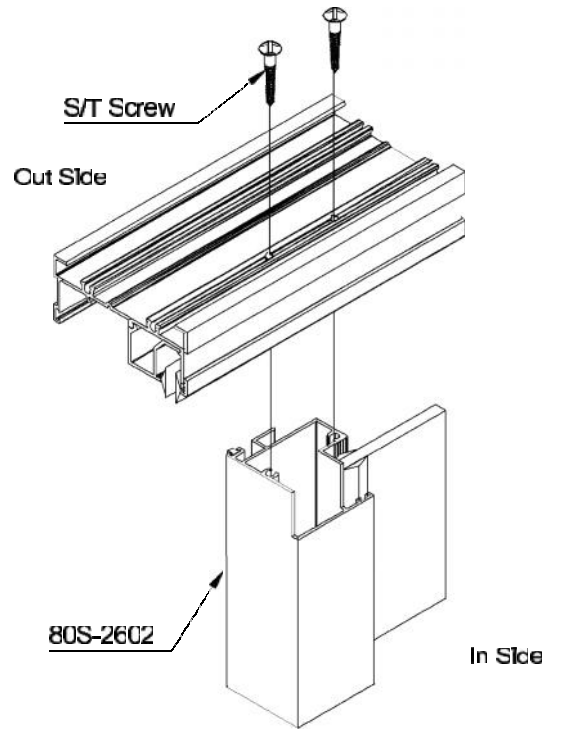
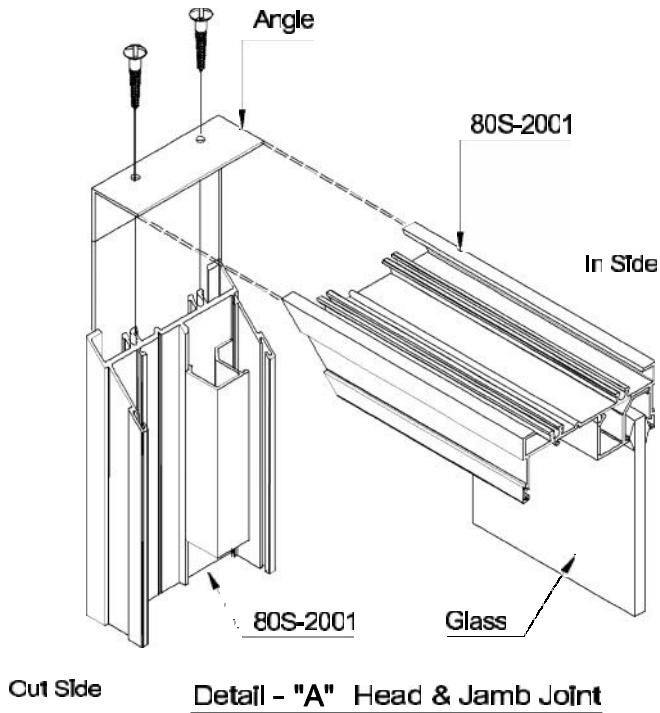

# 3D Assembly Detail Of 80mm Sliding Fixed

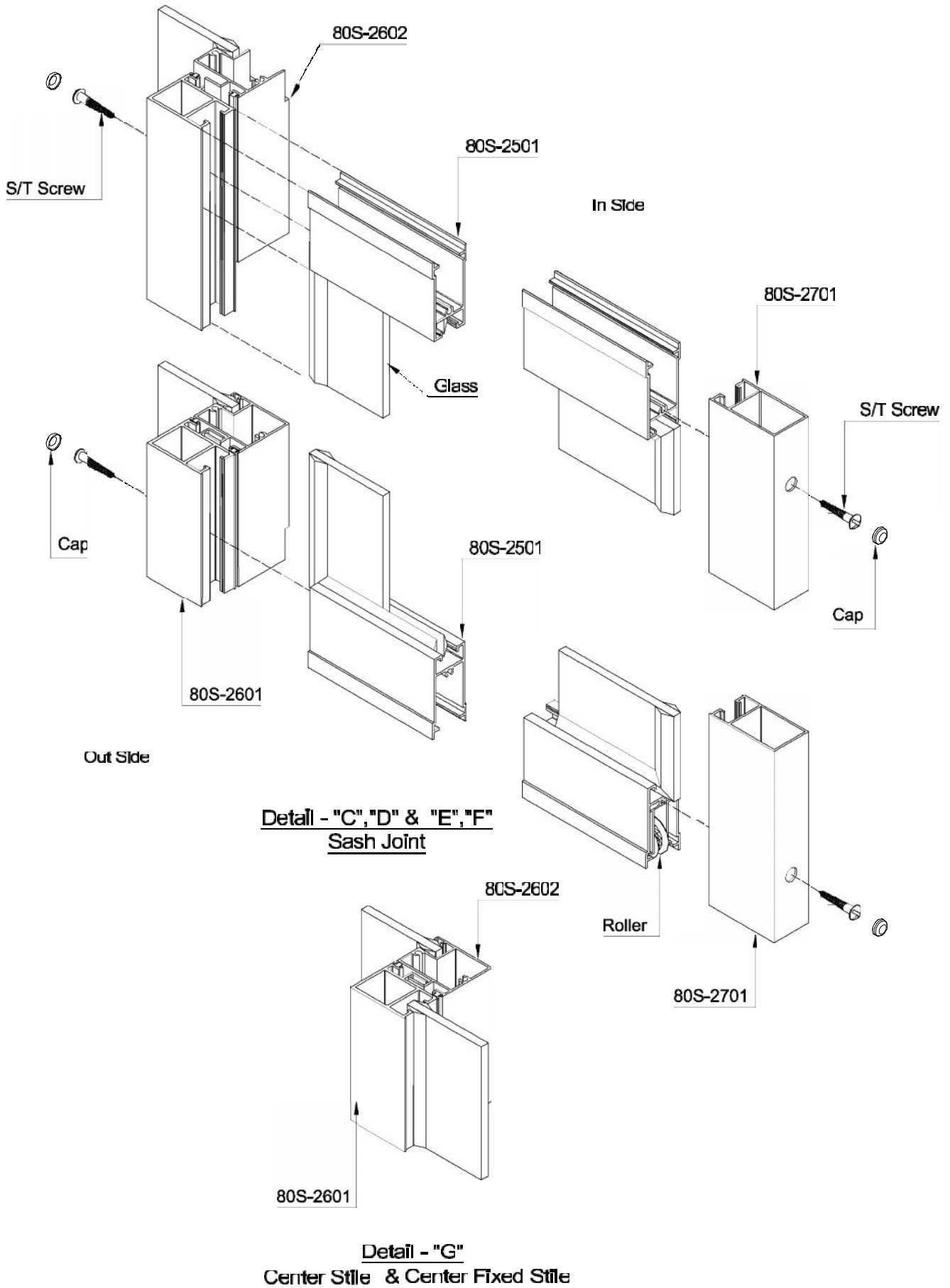

# 80mm Sliding & Fixed

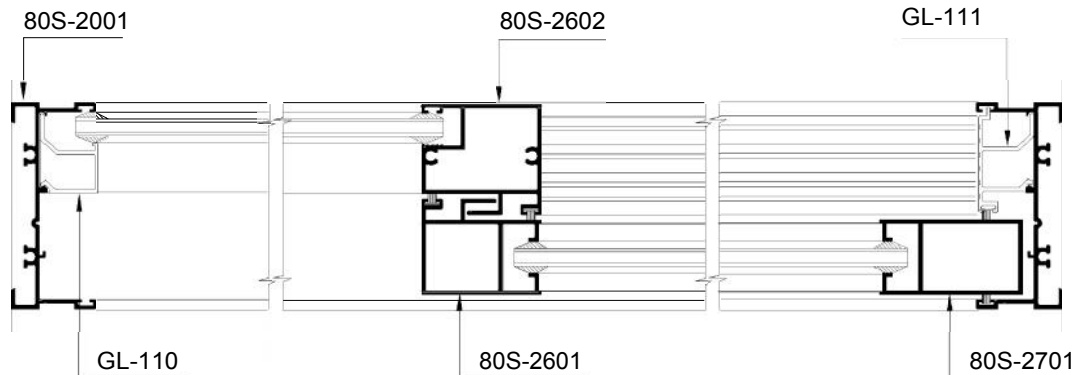
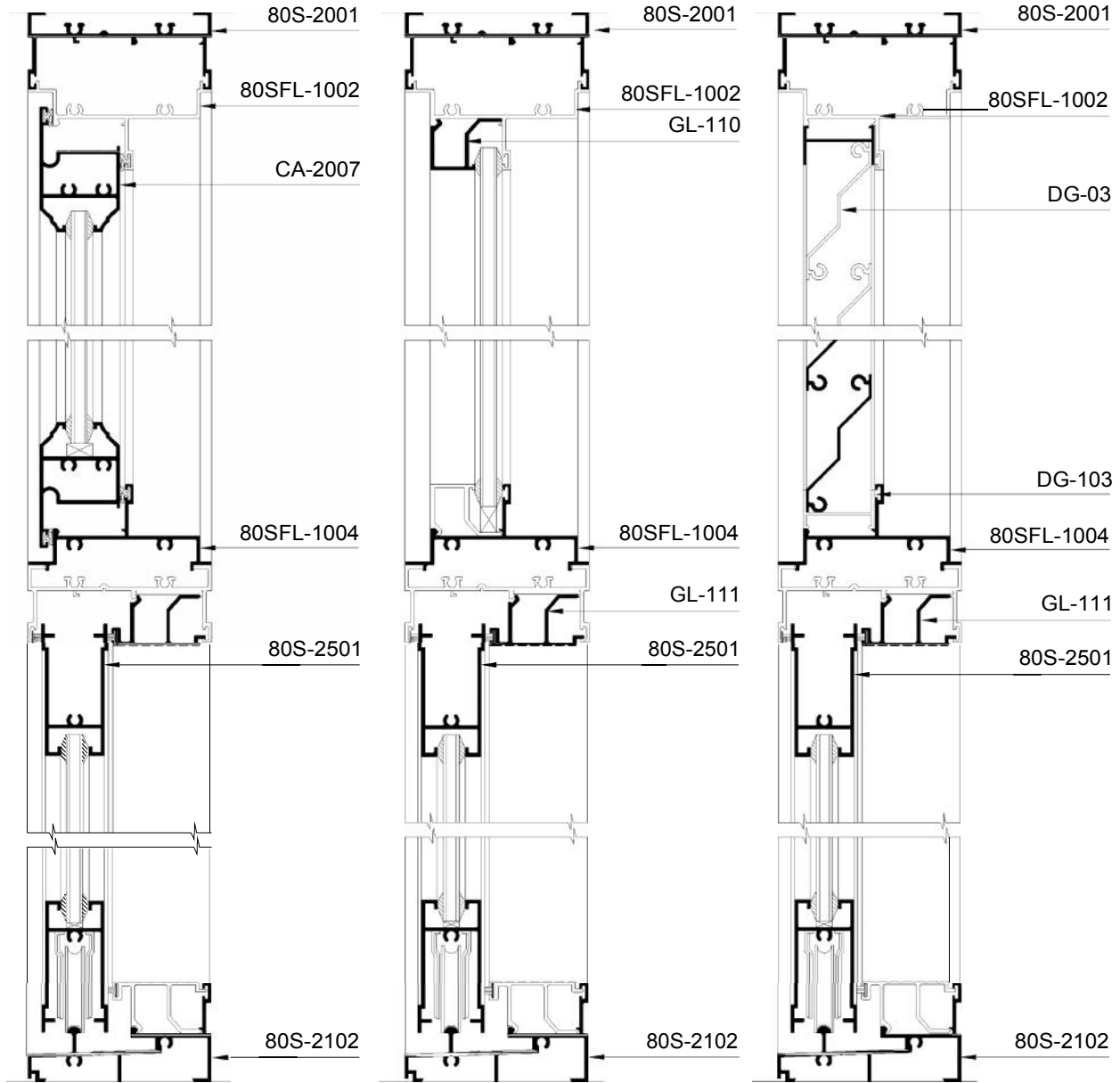



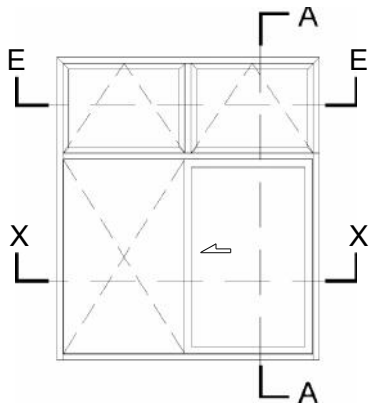

SLIDINGFIX WITH  
TOPHUNG

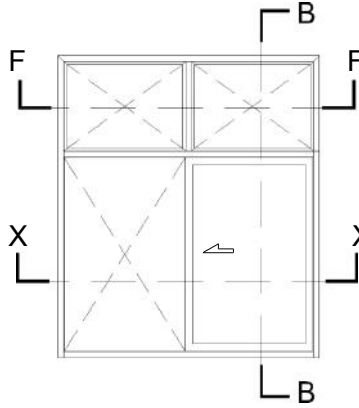

SLIDINGFIX WITH  
TOPFIXED

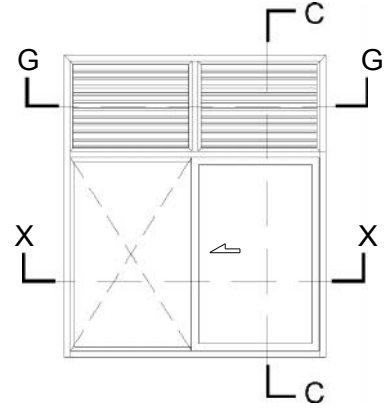

SLIDINGFIX WITH  
TOPLOUVER

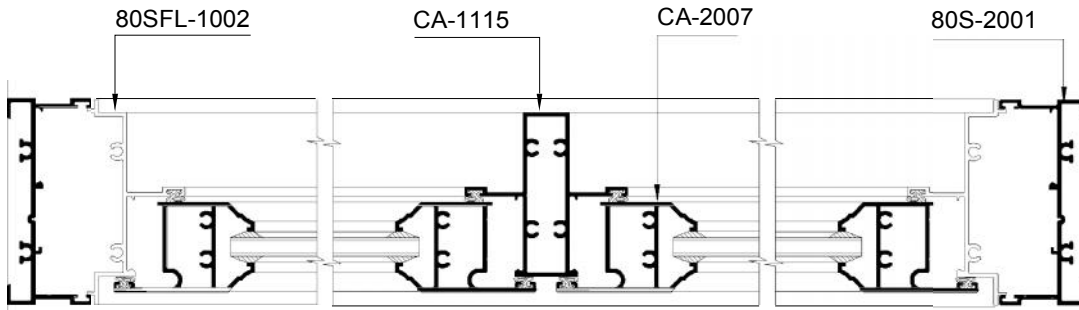

SECTION :- E - E

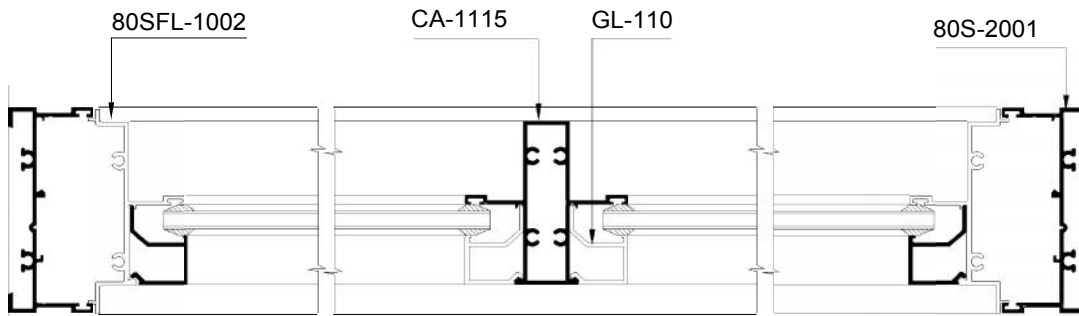

SECTION :- F - F

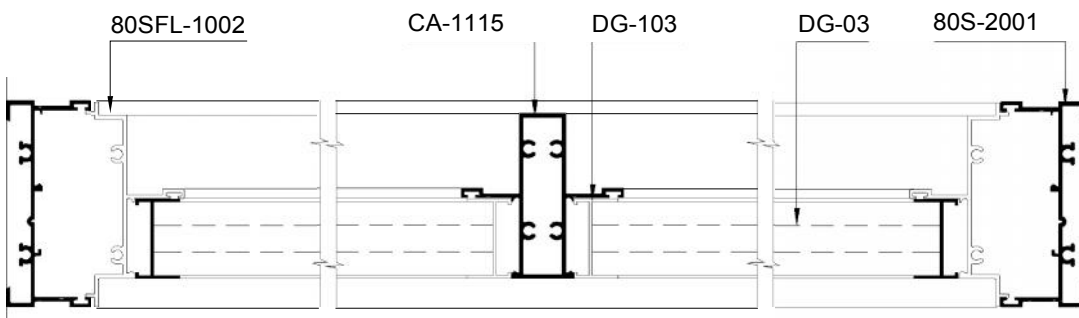

SECTION :- G - G

# 80mm Sliding & Fixed

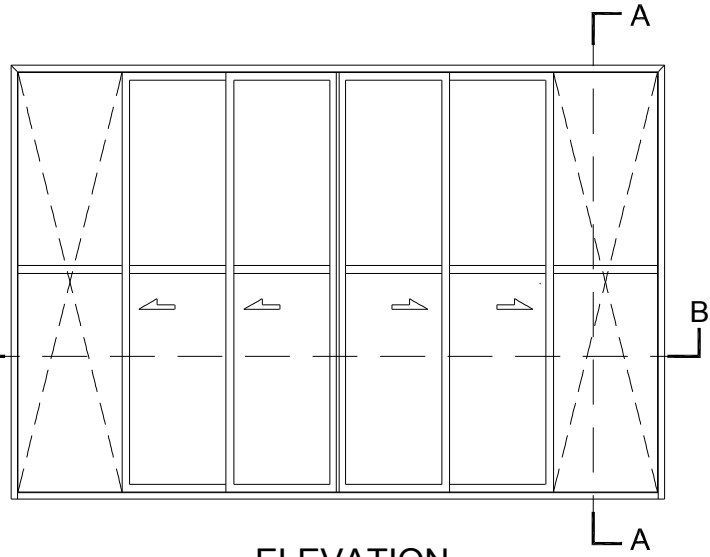
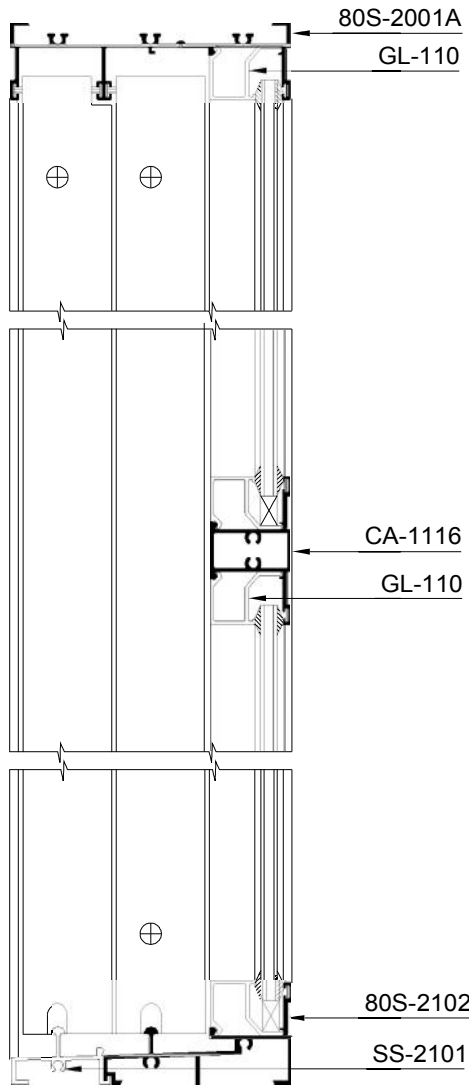

ELEVATION

SECTION: - A-A

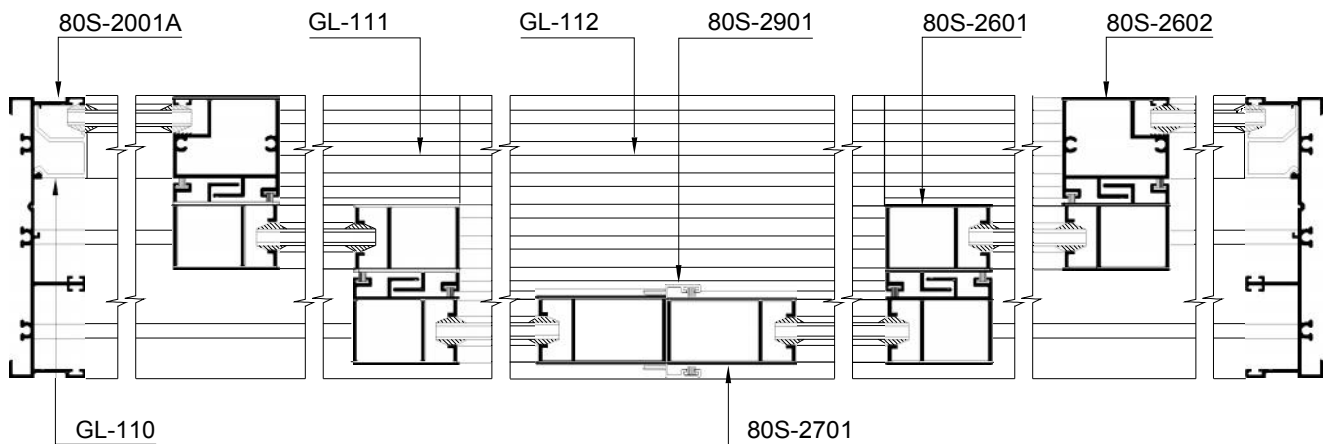

SECTION: - B-B

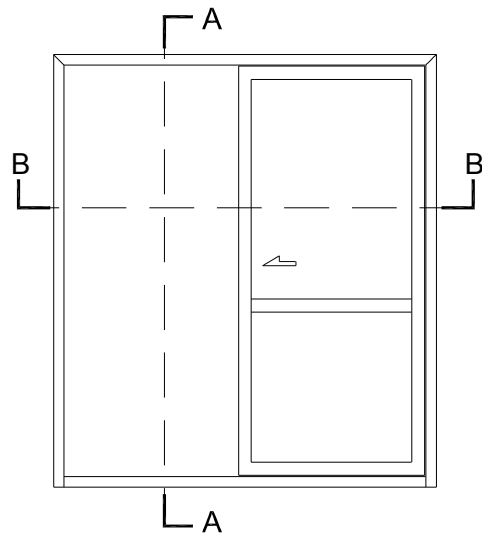
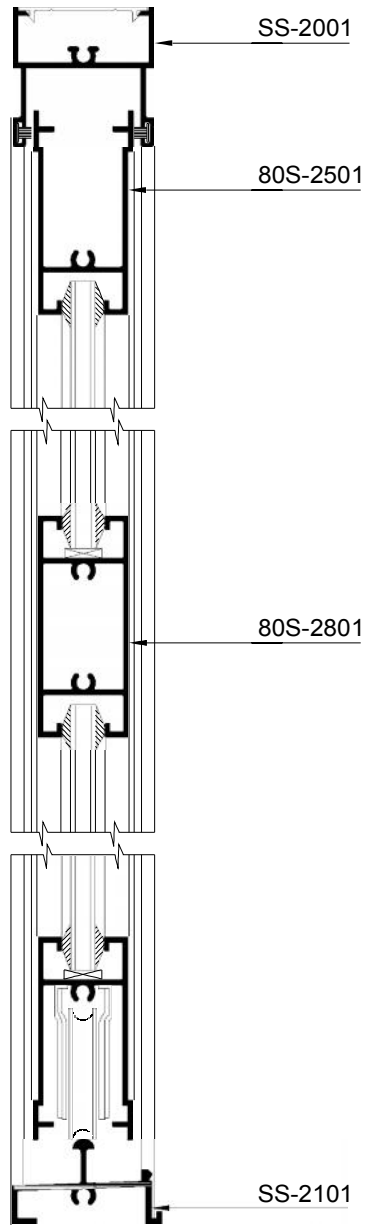

ELEVATION

SECTION:-A-A

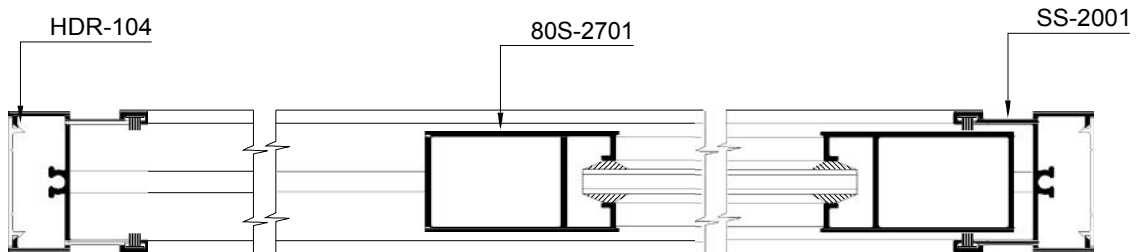

SECTION :- B - B

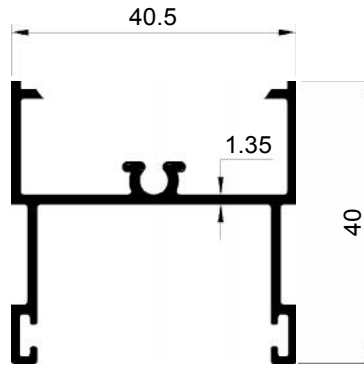

SECTION NO. - SS-2001  
EST. WEIGHT - 0.544 KG./M.

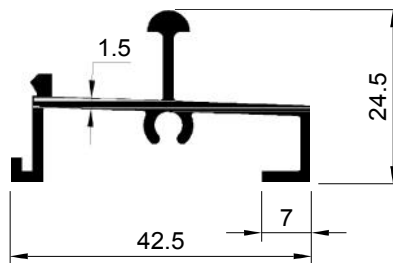

SECTION NO. - SS-2101  
EST. WEIGHT - 0.427 KG./M.

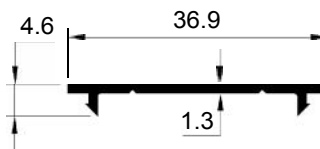

SECTION NO. - HDR-104  
EST. WEIGHT - 0.148 KG./M.